



Corporate Catalogue

CONTENT

3	•	About Us
4	•	Application Areas
5	•	Products
6	•	Battery Management Systems
7	•	Properties
8	•	Flx Series
10	•	Flx Series 3-5S BMS
10	•	Flx Series 6-10S BMS
11	•	Flx Series 11-15S BMS
12	•	Battery Packs
14	•	Applications
15	•	<i>Military Standart Solutions</i>
16	•	<i>Light Electric Vehicle Solutions</i>
17	•	<i>Consumer Electronics Solutions</i>
18	•	<i>Medical Battery Solutions</i>
19	•	<i>Industrial Solutions</i>
20	•	<i>Energy Storage System Solutions</i>
21	•	Product Testing and Certifications
22	•	Product Management Capabilities
23	•	Production Capabilities: Buy from the Manufacturer
23	•	R&D Services
24	•	Company Quality Management Certifications



ABOUT US

BPM¹ is the brand of Birikim Batteries Industry & Trade Co Ltd² which serves in the area of manufacturing battery packs, battery management systems and battery thermal management systems. It is headquartered in Istanbul, Turkey. Established in 2021 as a Research and Development center for the main company Birikim Batteries, BPM specializes in battery technology development. Being built on the heritage of Birikim Batteries with its 20-year-old experience, BPM quickly scaled up to become a competitive player in the Turkish market. As of today, BPM provides R&D, customized design, prototype development, product development, serial production, and maintenance services to multiple international customers.

Together with Birikim Batteries, BPM is among the largest battery solution-providers in the region. As the main company Birikim Batteries serves a wide and diverse customer base ranging from distributors to consumers and corporate customers, BPM takes over expertise in batteries, custom-designed-battery pack solutions, industrial batteries and battery packing equipment. Birikim Batteries has been serving to its customers with its experienced engineering teams and dedicated corporate sales teams for years and has multiple sales and service channels ranging from online trade platforms to multiple stores, and distributors around the region. BPM is now transferring this customer experience to focus on industries in strategic markets located in Europe, the Middle East, North Africa, and CIS countries.

BPM, The Strategic Regional Battery Technologies Provider

At BPM, we work together with the leading industrial players of Turkey and the region to provide R&D support for battery technologies. We support the manufacturers who use battery solutions in their production process or as a part of their product by enabling them to have their customized battery pack and battery management solutions. Our customers concentrate on LEVs (Light Electrical Vehicles), industrial equipment, the defense industry, consumer electronics & home appliances, hand-held tools, lighting, safety, AGVs (Automated Guided Vehicles), eVTOLs (Electrical Vertical Take-Off and Landing Vehicles) and medical industries. So as our application areas consist of their demands and private solutions for special needs.

As battery technologies become crucial in differentiating and gaining competitive advantage for various manufacturers, we keep investing in our R&D, production, and assembly facilities for developing best-of-breed products, solutions, and services. At the moment we are the largest and most reliable solution provider of our region for battery packing services with a well-established and certified quality inspection process.

As BPM, we are proud of having the largest battery product portfolio both in Turkey and in Europe. We access this large portfolio over our main company Birikim Batteries, who distributes and sells multiple global brands like Varta (Microbattery), Saft, Panasonic, LG, Murata, and FDK but also owns patents and regional battery brands like Power-Xtra.

Over the years, our main company Birikim Batteries managed to build a reputation of being the approved solution-provider of multiple global battery producers, the approved battery partner of hundreds of corporate customers, and the well-known provider of millions of end-users. BPM is now the technology center of Birikim Batteries and its expertise is in tailor-made solutions for our corporate customers. BPM is now the technology center of Birikim Batteries and its expertise is in tailor-made solutions for our corporate customers.

1 - BPM is a registered trademark of Birikim Pilleri Batarya Sanayi ve Ticaret LTD.ŞTİ. Istanbul Beyoğlu Tax Office 177 030 1096

2 - Birikim Batteries Industry & Trade Co Ltd refers to Birikim Pilleri Batarya Sanayi ve Ticaret LTD.ŞTİ. Istanbul Beyoğlu Tax Office 177 030 1096

Application Areas



Drone



Unmanned Aerial Vehicle



SIHA Armed Drone System

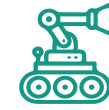

IKA Bomb Disposal Vehicle

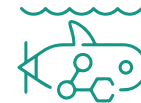

IDA Unmanned Underwater Vehicle



E-Scooter



Automated Guided Vehicle



E-Bike



Golf Cart



Autocycle



Forklift



Pallet Truck



E-Handicapped Chair



Portable Energy Storage



Medical Equipment



Caravan



Stationary Energy Storage



Telecommunication



Marine Technologies

PRODUCTS

- Battery Management Systems
- Battery Packs

About BPM Battery Management System (BPM BMS)

A key element in Li-ion battery applications is the capability to monitor, control, and optimize the performance of an individual or multiple battery modules and the ability to control the disconnection of the module(s) from the system in case of abnormal conditions. This management scheme is known as “battery management system (BMS)”, and is one of the most critical components in any electrical equipment. A BMS reacts both with internal and external conditions and it helps to improve the battery performance of proper safety measures within a system. A BMS contains integrated circuits, sensors, controllers and similar components. Primary functions are cell and battery voltage and temperature protection during charge and discharge, balancing cell voltage, tracking individual cell performance, battery health and charging capacity forecasting, inspecting battery failure. BMS provides system safety, improves performance, extends battery lifetime and therefore the additional cost of having a BMS in a battery pack is always justified.



PROPERTIES

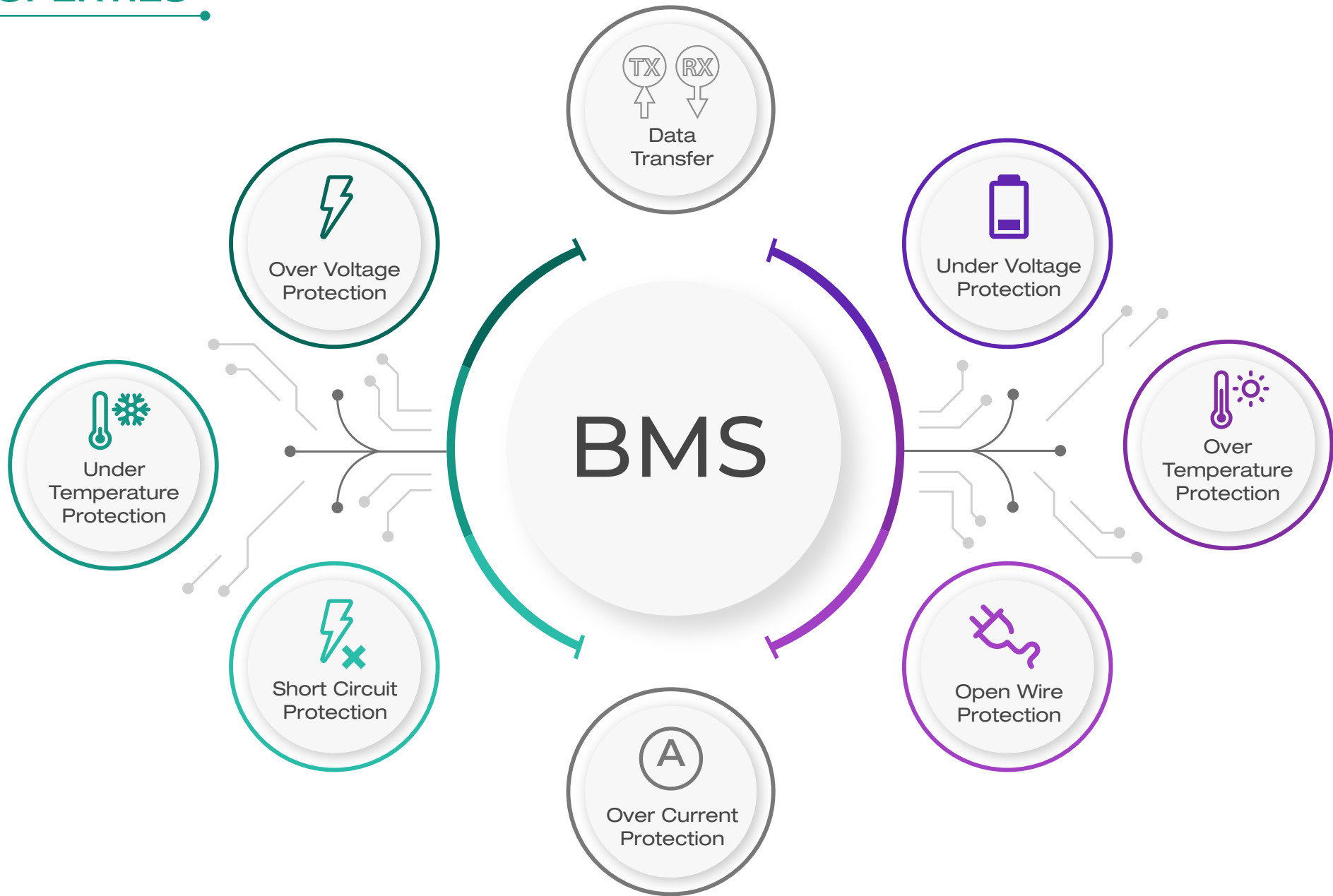

FLX SERIES

Our Flex series is designed to support various applications ranging from consumer electronics to home appliances, medical, healthcare and light electrical vehicles. With its small dimensions and light weight, Flex series is designed for high accuracy and low current consumption. Flex allows serial connection for packages with various numbers of cells with only a single circuit. For Flex the primary focus is reliability and security. The product will provide superior performance especially for e scooters, e-bikes, AGVs, golf carts, power tools, garden tools, robotic cleaners, vacuum cleaners and hover boards.

FLX SERIES

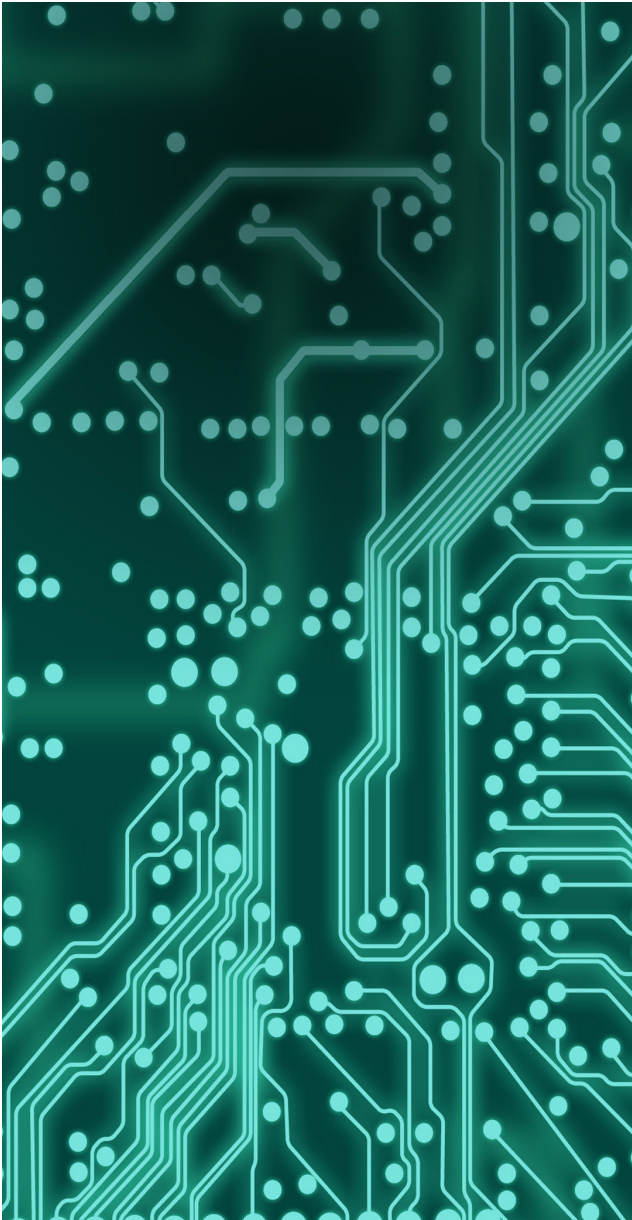

- ✓ **Supporting Battery Types:** Li-ion, Li-Polymer, Li-FePO4
- ✓ **Series Cells:** 3 to 20
- ✓ **Smart Integrated Cell Balancing:** 50mA, passive balance
- ✓ **Operating Temperature:** -20 °C to +85 °C
- ✓ **SHUTDOWN Mode:** 0.5- μ A Maximum
- ✓ Overcharge Voltage Protection(OV)
- ✓ Overdischarge Voltage Protection(UV)
- ✓ Overcharge Current Protection(OCC)
- ✓ Overdischarge Current Protection(OCD)
- ✓ Over Temperature Charge(OTC)
- ✓ Under Temperature Charge(UTC)
- ✓ Over Temperature Discharge(OTD)
- ✓ Under Temperature Discharge(UTD)
- ✓ Open Cell And Open-Wire Detection(OW)
- ✓ Short-Circuit Discharge Protection(SCD)
- ✓ Ultra-Low Quiescent Current
- ✓ Possibility to have multiple battery options for different customer type and usage
- ✓ Adjustable current, voltage and temperature limit values
- ✓ Ultra-low power HIBERNATE mode for shipping and storage

FLX SERIES 3S/4S/5S BMS

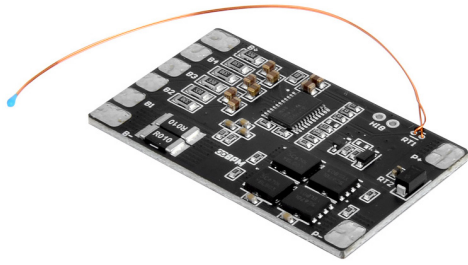

- This protection board is lithium battery protection board in 3s/4s/5s common use.
- Adjustable Over/Under Voltage Limit (3.8V – 4.25V / 2.5V - 2.9V)
- Adjustable Charge/Discharge Current Limit (4A – 8A)
- Adjustable Over/Under Temperature Limit (70 °C / -20 °C)
- 4 different modes (normal, shutdown, hibernate, fault)
- 1 NTC for protection and 1 NTC for measurement pcb board
- Ultra-Low Quiescent Current
- BMS manufactured by high quality Mosfet and IC imported
- The system can be easily configured to customer-specific application
- Extremely small dimensions (30x50mm)

FLX SERIES 6S/7S/8S/9S/10S BMS

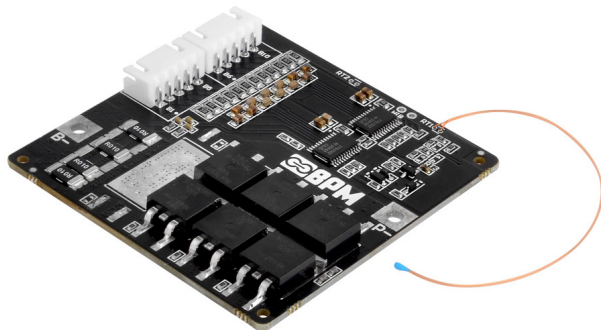

- Extremely small dimensions (65x65mm)
- A single circuit for all battery groups between 6 and 10 cells.
- Adjustable Over/Under Voltage Limit (3.8V – 4.25V/ 2.5V - 2.9V)
- Adjustable Charge/Discharge Current Limit (4A – 20A)
- Adjustable Over/Under Temperature Limit (70 °C / -20 °C)
- Possibility to have multiple battery options for different customer type and usage
- Suitable for continuous and pulse current
- Capable of operation in an extended temperature range (-20 °C to +85 °C).
- 4 different modes (normal, shutdown, hibernate, fault).
- Ultra high precision

FLX SERIES 11S/12S/13S/14S/15S BMS

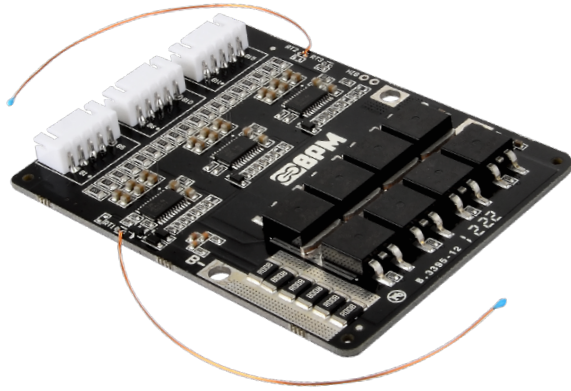

- Ultra high precision and accuracy
- This protection board is lithium battery protection board in
- 11s/12s/13s/14s/15s common use.
- Adjustable Over/Under Voltage Limit (3.8V – 4.25V / 2.5V – 2.9V)
- Adjustable Charge/Discharge Current Limit (10A – 40A)
- Adjustable Over/Under Temperature Limit (70 °C / -20 °C)
- Possibility to have multiple battery options for different customer needs and usages
- Charge-discharge current path separation
- Extra heatsink for circuit thermal management
- Suitable for continuous and pulse current
- Ultra-Low Quiescent Current
- Capable of operation in an extended temperature range
- (-20 °C to +85 °C).
- 3 trackable NTC for measurement battery temperature
- 4 different modes (normal, shutdown, hibernate, fault).

About Battery Packs

The design, performance and safety of the battery pack has become extremely important in all industries where energy storage is required. The battery pack has direct impact on the commercial success of the device, application and / or product.

Here at BPM, we serve our customers depending on their go-to-market strategies. If our customer needs a custom-designed battery pack, we run special projects and provide the best-fitted-solution. If our customer is seeking a consultancy for good quality and also needs a cost-efficient solution. we are also able to offer standardized solutions.

With our 17 years of expertise in battery market we manufacture batteries in various technologies like lithium-ion, Ni-Cd, Ni-MH, Li-SOCl₂, lithium polymer and more regarding to customer needs. In addition to the battery packs we also provide battery management systems, protection modules, battery thermal management systems and specialized chargers.

Our production facility in Istanbul Turkey is 2000 square meters and we hold First Quality Certification for ISO 9001, ISO 14001 and OHSAS 18001. At our premises, safety comes first and we fulfill all environmental requirements for a sustainable future.

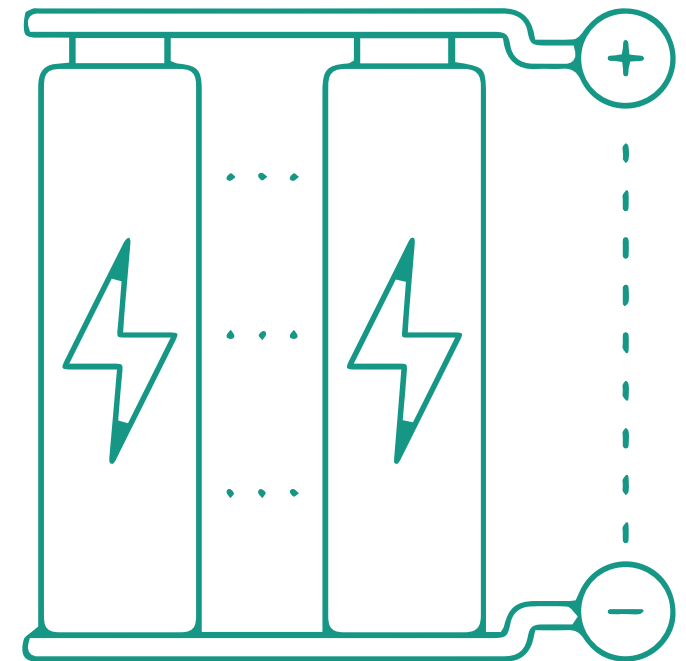

BATTERY PACKS

With a team of experienced engineers, we provide end to end services starting from customer requirement analysis to battery pack design, testing, prototype production and serial production. During the design phase we focus on the application area requirements as much as the battery design.

BPM Battery Pack is offered with:

- ✓ Special design service and R&D support
- ✓ Design and assembly of all battery components
- ✓ Approved capacity guarantee
- ✓ Final product quality control,
- ✓ Condition, performance and durability testing
- ✓ Battery life test at cell / module / package level
- ✓ BMS technology and support
- ✓ On-site consultancy and support services

BPM aims to be the first brand that comes to mind when there is a battery pack need. You can contact with us via our web-site to learn more.

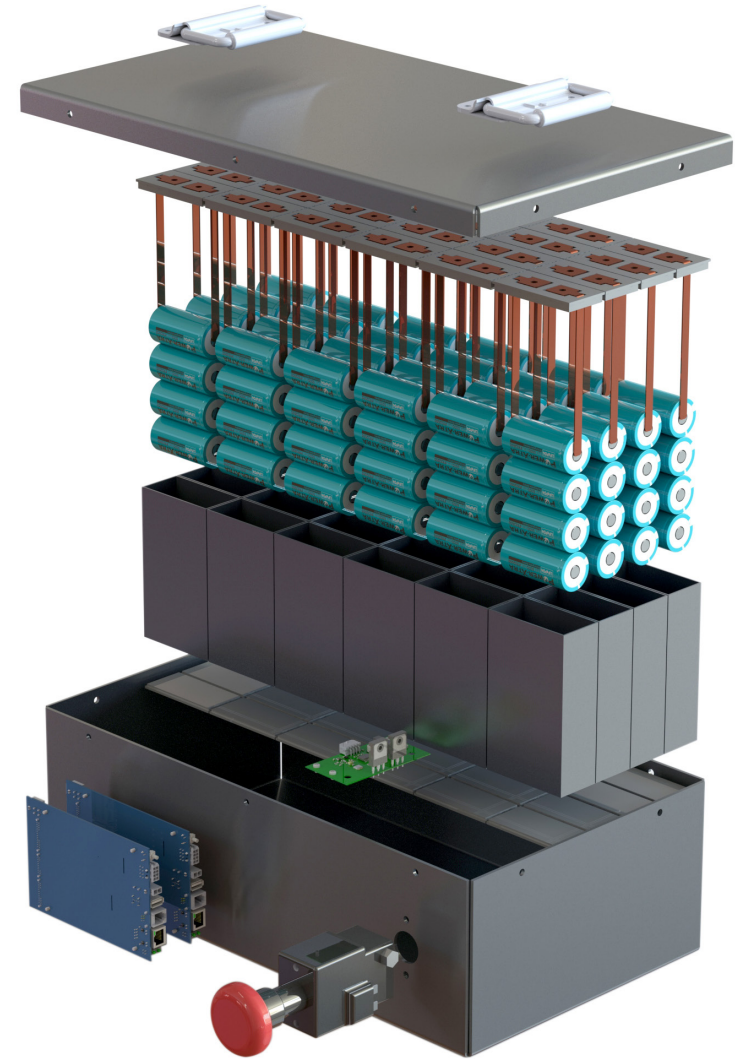

APPLICATIONS

- Military Standart Solutions
- Light Electric Vehicle Solutions
- Consumer Electronics Solutions
- Medical Battery Solutions
- Industrial Solutions
- Energy Storage System Solutions

Military Standart Solutions

We serve more than 200 customers in the defense industry with our wide product and solution portfolio. We are creating success stories. To our nearly 90 customers, we provide services from UAV to SiHA, from iDA to SiDA, from drone to radio, from cap to night vision control batteries for many applications, from binoculars to external tanks to rocket control units.

We have provided various products such as memory batteries for helicopters. The services we provide are not only limited to sales, but also ensure that our customers use our products safely for many years. In order to ensure their use, it extends from R&D to maintenance and repair after sales.

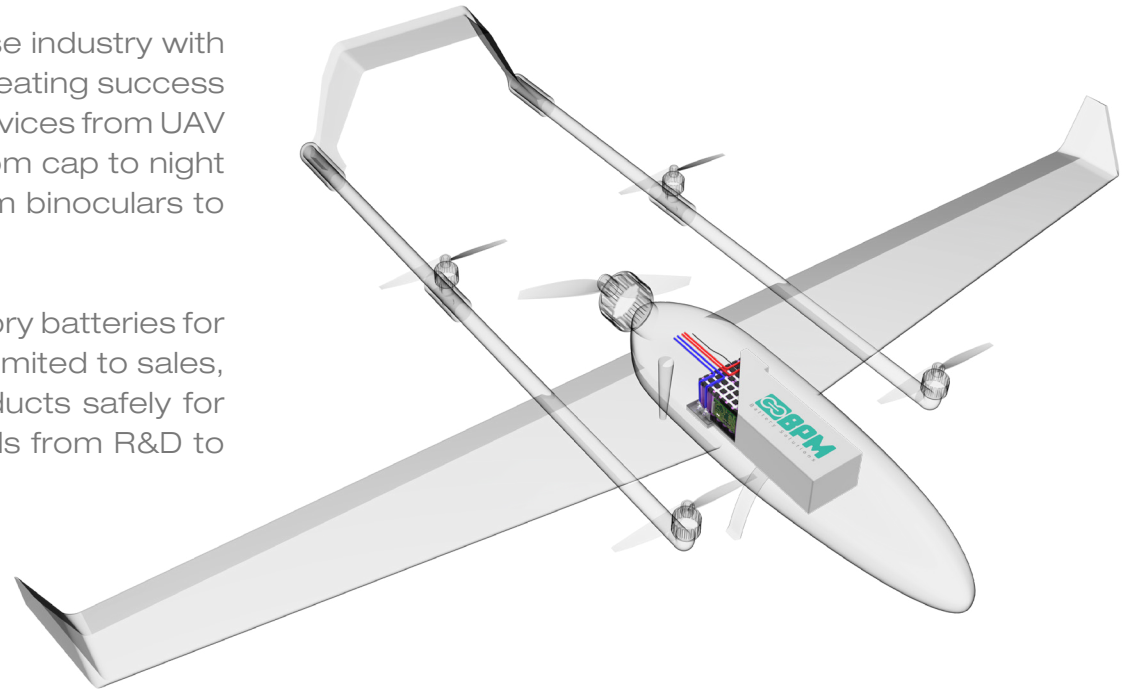

Light Electric Vehicle Solutions

The use of light electric vehicles is increasing day by day. In the near future, batteries will provide power and movability in long ranges to millions of electric transportation vehicles. E-mobility is here to stay and grow. As BPM, we enjoy being part of this transition. We designed our first battery packs for e-bikes and e-scooters back in 2014 and since 2017 we supply battery solutions for our customers within a wide-range of products. We prefer to specialize in the light electric vehicles segment and this gives us a competitive edge. Our customers receive tailor-made solutions and efficient services.

Over the years we focused on two pillars; driving down the cost of the battery pack and producing lighter and safer batteries.

Today BPM:

- ✓ has a wide product range to meet various battery and battery management system needs
- ✓ supports customers with R&D team and engineers
- ✓ has the capability to provide custom designed batteries
- ✓ has the largest test center in MEA region
- ✓ products go through quality control stages before delivery
- ✓ products come with real capacity guarantee
- ✓ provides after sales services & support
- ✓ provides supportive batteries for communication systems
- ✓ takes overall responsibility for the entire battery pack system.

Light Electrical Vehicle Applications

BPM provides maximum performance for light electric vehicles such as e-bikes, scooters, golf carts, forklifts, and several similar applications.

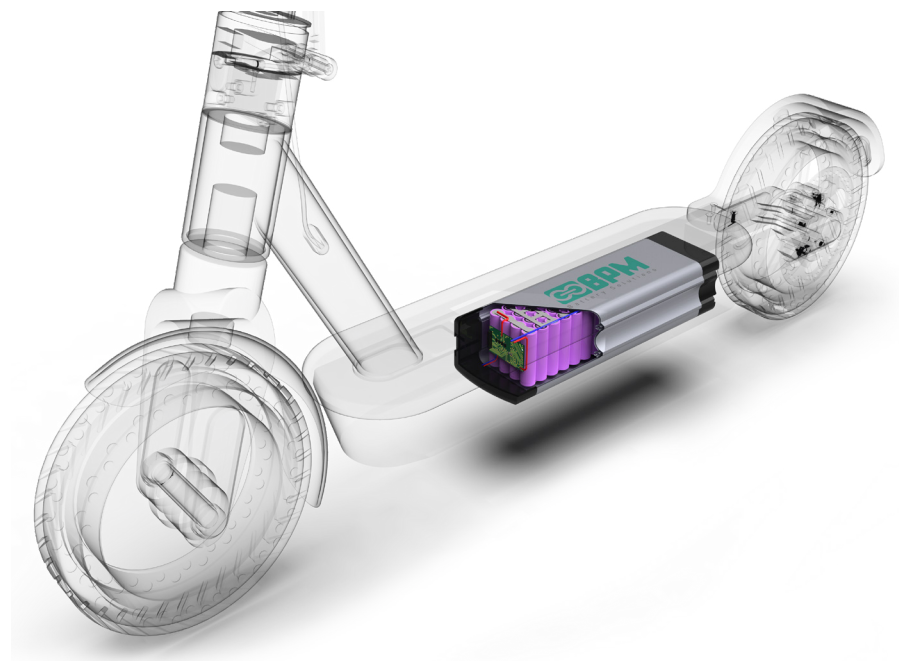

Consumer electronics require innovative, reliable, safe batteries with high capacity, high energy density, long life-cycle, and high charge/discharge capabilities. The manufacturer must design batteries which are adoptable and scalable over time. Most of the time, the market is competitive and the battery pack needs to be cost-efficient. However, there is no way to compromise on safety.

Since 2009, we provide battery solutions to more than 50 manufacturers. We designed and produced various batteries ranging from home appliances such as portable vacuum cleaners and robot vacuum cleaners to electronic toys, drones, radios, walky-talkies and hand drillers.

Consumer Electronics Applications

BPM supports various home appliances, portable vacuum cleaners, robot vacuum cleaners, electronic toys, drones, radios, walky-talkies, hand drillers and more.

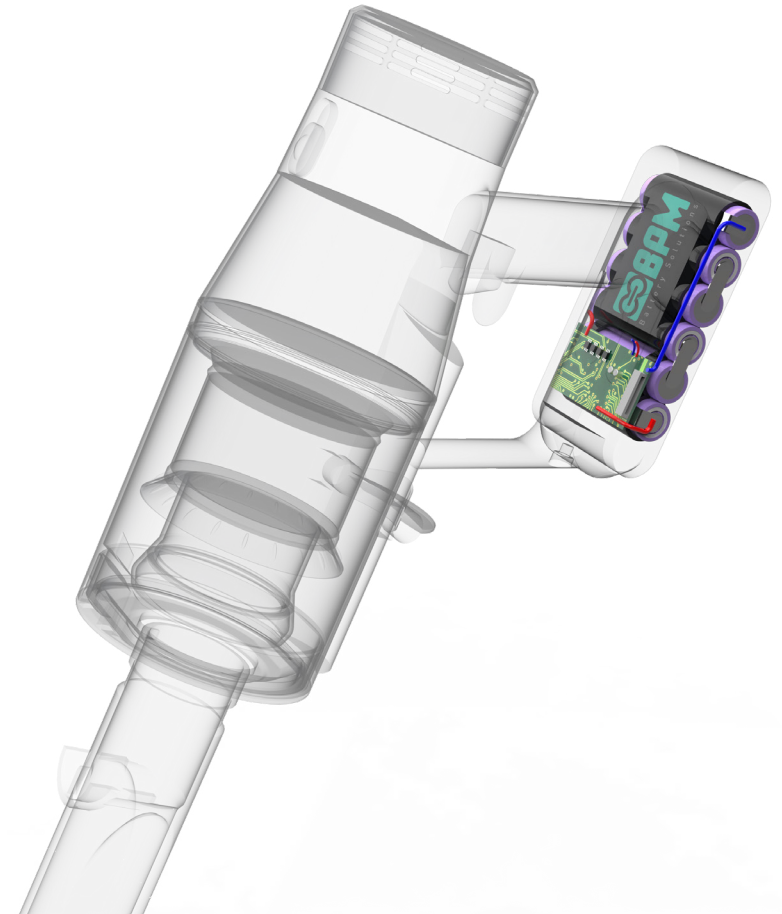

We serve more than 400 customers in the medical industry, ranging from hospital chains to regional equipment manufacturers. Our solid knowledge on the medical devices battery solutions is a result of this large customer profile. The experience we have in the medical field applications demonstrates itself especially in hospitals for our customers which also enables us to have a very good understanding of the end product's price/ performance expectations. This solid experience in medical industry makes us the approved partner of medical equipment manufacturers.

We serve our customers in medical battery solutions by designing, developing, testing and manufacturing custom products for the specific needs of almost all medical devices and applications with unique power requirements. BPM supports the entire system for safe and reliable battery performance in mission critical medical applications.

Medical Battery Applications

BPM offers integrated solutions for a wide variety of medical applications including ECG equipment, defibrillators, aspirators & ventilators, monitors, medical emergency and transport equipment, operating room equipment like AGMs, surgical tables, dentist desks.

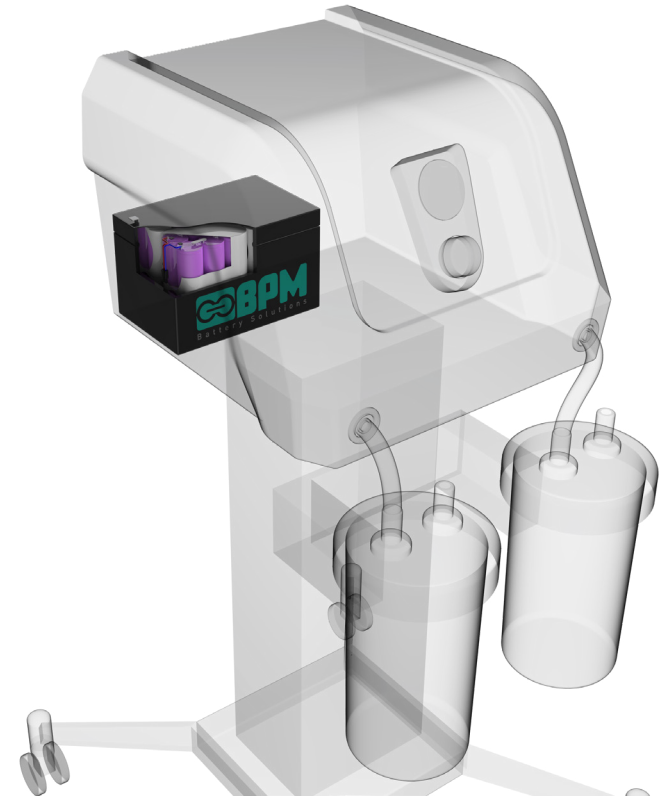

Industrial applications require high power and reliable batteries that can withstand extreme conditions. In most industrial applications the unique power requirements must be met. Therefore, the batteries used in these demanding applications could not be selected from ordinary batteries. Our customers need the most reliable and the most cost efficient solutions.

As the official distributor of the world's most respected battery manufacturers, we meet the battery needs of our customers concerning to their different industrial needs. We set high quality and longevity standards and take the responsibility for the entire system.

Industrial Applications

BPM produces batteries for various applications like CNC machines, smart control systems, robotic systems, drills, GPRS, tracking systems, tachograph devices, vehicle tracking systems, electronic toll booths, data recorders, vending machines and GSM POS equipment.

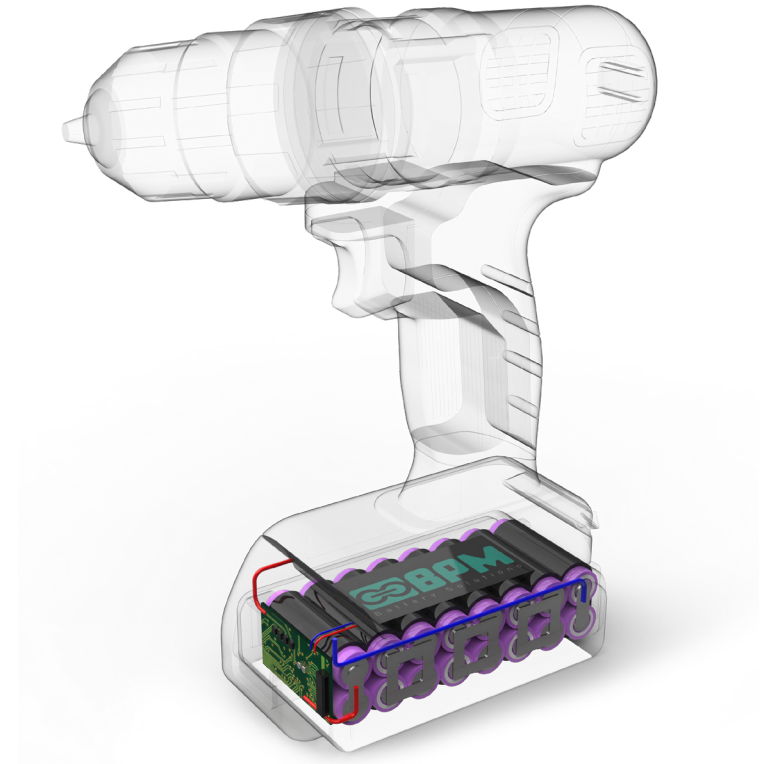

Energy Storage System Solutions

The need of energy storage increases sharply as renewable energy installations expand. Energy independency, efficiency, reliability and cost-effective production are in the agenda of millions. End-users install PVs and rooftops and at BPM we build battery solutions that will serve a wide section of the market.

The energy battery market is full of products that are too big for the majority of consumers. Customers need convenient, reliable and cost-efficient solutions. We propose energy storage solutions that are small enough to handle the needs of 12W customer applications yet scalable enough to handle 1MW or even larger applications. BPM battery solutions can bridge the gap between no storage and too much storage and we can optimize down to very small storage sizes to increase your investment's payback.

With our engineering teams we build customized battery solutions to ensure high capacity, high energy density, long life-cycle, and high charge/discharge capabilities. BPM is the right partner with its one of a kind product services and customer support.

Our solutions are

- ✓ customized,
- ✓ scalable
- ✓ cost efficient,
- ✓ certified for safety

Energy Storage System Applications

BPM provides scalable energy storage systems supporting a wide range of applications ranging from solar panels to small scale wind applications and home battery storage systems.

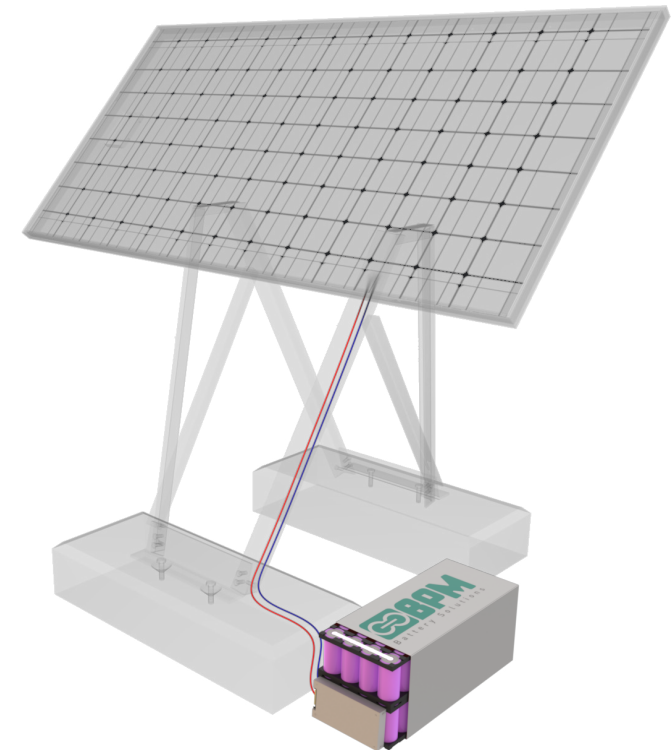

Product Testing and Certifications

Test Services

- ✓ Accumulators, Cell and Battery Tests
- ✓ BMS Tests,
- ✓ Capacitor Tests,
- ✓ Life-Cycle Tests,
- ✓ Currency Cut-Out Control Tests,
- ✓ Balance Tests
- ✓ Climate Cabin Tests

Test Capacity Details

- ✓ Test Capacity: Up to 100V 400A
- ✓ Climate Cabin Capacity: From -40°C to +100°C
- ✓ Test Machines : 19 pcs
- ✓ Test Channels: 130 pcs

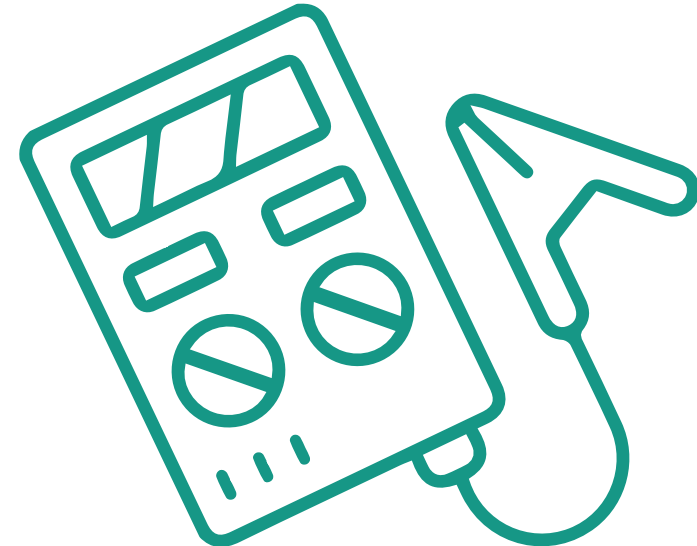

Battery Chemistry	Standard Number	Standard Header
Li-ion	EN 62620:2015	Secondary cells and batteries containing alkaline or other non-acid electrolytes - Secondary lithium cells and batteries for use in industrial applications
Nickel-Cadmium (Ni-Cd)	IEC 61951 1:2017	Secondary cells and batteries containing alkaline or other non-acid electrolytes - Secondary sealed cells and batteries for portable applications - Part 1: Nickel-Cadmium
Nickel-Metal Hydride (Ni-Mh)	IEC 61951-2:2017	Secondary cells and batteries containing alkaline or other non acid electrolytes - Secondary sealed cells and batteries for portable applications - Part 2: Nickel-metal hydride
Lead-acid	IEC 61056-1:2012	General purpose lead-acid batteries (valve-regulated types) - Part 1: General requirements, functional characteristics - Methods of test

Product Management Capabilities

- ✓ 1400+ Different product designs per year,
- ✓ Material management system,
- ✓ Battery system design,
- ✓ 3D Battery mechanical design,
- ✓ Prototyping with 3D printer and manufacturing,
- ✓ Label-design, printing and marking services fro private-labels,
- ✓ Designing battery packs (more than 40 solid schemes, customization option is available),
- ✓ Preparation of production assembly files and product datasheets,
- ✓ Robot, drone, e-bike, AGV, healthcare, military and industrial battery designs,
- ✓ BMS adoption.



Production Capabilities: Buy from the Manufacturer

- ✓ Manufacturer of battery management system(BMS)s,
- ✓ Production line: 800 m²,
- ✓ 8 Production - Test Engineer / 22 Operator - Technician,
- ✓ 2.000.000 cell grouping capacity per year,
- ✓ Battery Grouping Chemistry Types: Ni-Cd, Ni-MH, Lithium, Lithium-ion, LiFePO₄,
- ✓ Digital resource and process management,
- ✓ Product tracking with serial number and barcode,
- ✓ Our automations: automatic battery sorting, automatic spot welding.

R&D Services

With more than 15 engineers, we provide solutions for a better future in battery solutions. Please contact to our sales teams for details or fill the form in our web-site to contact with our experts.



Company Quality Management Certifications

CERTIFICATE

kiwa

Birikim Pilleri
BİRİKİM PİLLERİ BATARYA
TEKNOLOJİLERİ A.Ş.

HQ: İTOŞB TEPEÖREN MAHALLESİ RECEP BİLAL HANCI CD. NO: 4/20 TUZLA - İSTANBUL - TÜRKİYE
BRANCH: TEPEÖREN MAHALLESİ İ.T.O.S.B 4. CADDE NO: 8 TUZLA - İSTANBUL - TÜRKİYE

with a scope of

VARIOUS BATTERY GROUPING, BATTERY PACK MANUFACTURING AND GROUPING

ISO 9001:2015
Has established a quality management system in accordance with international standard.

"Following elements of the standard are excluded"
None

Certificate No : M 12107
Initial Certification Date : 19 July 2024
Certification Date : 19 July 2024
Expiration Date : 18 July 2027

kiwa Belgelendirme Hizmetleri A.Ş.
İTOŞB 9. Cadde No. 15 Tepeören Tuzla
İstanbul / Turkey

Tel: + 90 216 593 25 75
Faks: + 90 216 593 25 74
info@kiwa.com.tr
www.kiwa.com.tr

General Manager

IAF
TÜRKAK
TÜRKAK BDS NO
YS-F335-0853
AB-0006-YS

Certificate is valid till expiration date, subject to successful completion of periodical surveillance audits. Please contact above numbers for detailed information.

Last Modified : 19 July 2024 - R 00

CERTIFICATE

kiwa

Birikim Pilleri
BİRİKİM PİLLERİ BATARYA
TEKNOLOJİLERİ A.Ş.

HQ: İTOŞB TEPEÖREN MAHALLESİ RECEP BİLAL HANCI CD. NO: 4/20 TUZLA - İSTANBUL - TÜRKİYE
BRANCH: TEPEÖREN MAHALLESİ İ.T.O.S.B 4. CADDE NO: 8 TUZLA - İSTANBUL - TÜRKİYE

with a scope of

VARIOUS BATTERY GROUPING, BATTERY PACK MANUFACTURING AND GROUPING

ISO 14001:2015
Has established an environmental management system in accordance with international standard.

Certificate No : M 12108
Initial Certification Date : 19 July 2024
Certification Date : 19 July 2024
Expiration Date : 18 July 2027

kiwa Belgelendirme Hizmetleri A.Ş.
İTOŞB 9. Cadde No. 15 Tepeören Tuzla
İstanbul / Turkey

Tel: + 90 216 593 25 75
Faks: + 90 216 593 25 74
info@kiwa.com.tr
www.kiwa.com.tr

General Manager

IAF
TÜRKAK
TÜRKAK BDS NO
YS-6756-0DAB
AB-0006-YS

Certificate is valid till expiration date, subject to successful completion of periodical surveillance audits. Please contact above numbers for detailed information.

Last Modified : 19 July 2024 - R 00

CERTIFICATE

kiwa

Birikim Pilleri
BİRİKİM PİLLERİ BATARYA
TEKNOLOJİLERİ A.Ş.

HQ: İTOŞB TEPEÖREN MAHALLESİ RECEP BİLAL HANCI CD. NO: 4/20 TUZLA - İSTANBUL - TÜRKİYE
BRANCH: TEPEÖREN MAHALLESİ İ.T.O.S.B 4. CADDE NO: 8 TUZLA - İSTANBUL - TÜRKİYE

with a scope of

VARIOUS BATTERY GROUPING, BATTERY PACK MANUFACTURING AND GROUPING

ISO 45001:2018
Has established an occupational health and safety management system in accordance with standard.

Certificate No : M 12109
Initial Certification Date : 19 July 2024
Certification Date : 19 July 2024
Expiration Date : 18 July 2027

kiwa Belgelendirme Hizmetleri A.Ş.
İTOŞB 9. Cadde No. 15 Tepeören Tuzla
İstanbul / Turkey

Tel: + 90 216 593 25 75
Faks: + 90 216 593 25 74
info@kiwa.com.tr
www.kiwa.com.tr

General Manager

IAF
TÜRKAK
TÜRKAK BDS NO
YS-7CDA-A820
AB-0006-YS

Certificate is valid till expiration date, subject to successful completion of periodical surveillance audits. Please contact above numbers for detailed information.

Last Modified : 19 July 2024 - R 00

Notes



+90 (216) 629 90 60

www.bpmbattery.com

info@bpmbattery.com

All rights reserved. |2022|